

PUBLIC



KONGSBERG

Instruction Manual

M3 Sonar®

Creating an image mosaic using SAMM

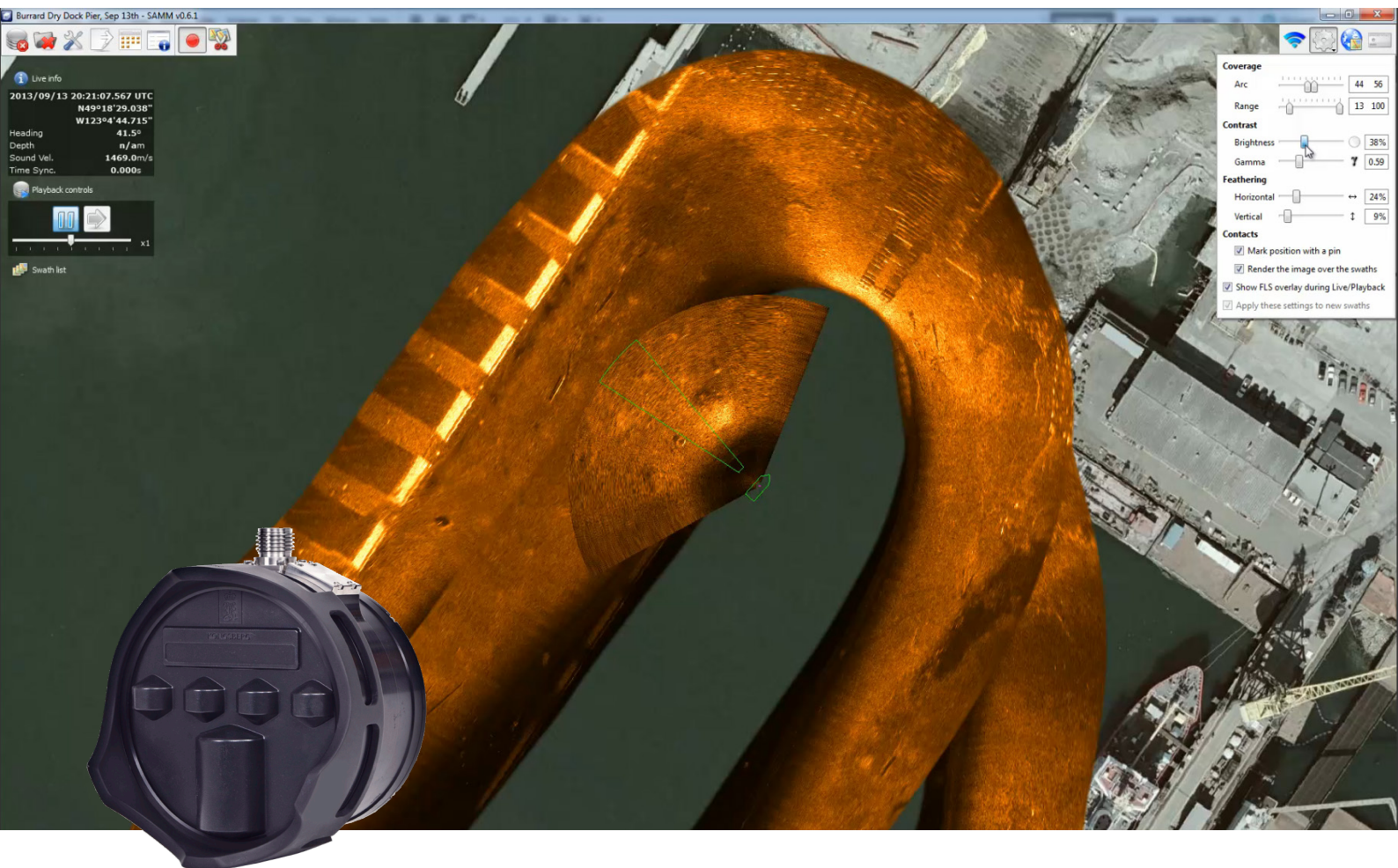



KONGSBERG

M3 Sonar
Interfacing with SAMM
Instruction Manual
Release 1.1

This manual provides the basic information required to create an image mosaic using SAMM software.

You will learn how to collect image data that will be combined into a mosaic of multiple overlapping geo-referenced images.

922-20007012/1.1

April 2024 © Kongsberg Discovery
Canada Limited

Document information

- **Product:** Kongsberg M3 Sonar
- **Document:** Instruction Manual
- **Document number:** 922-20007012
- **Revision:** 1.1
- **Date of issue:** 19 April 2024

Copyright

The information contained in this document remains the sole property of Kongsberg Discovery Canada Limited. No part of this document may be copied or reproduced in any form or by any means, and the information contained within it is not to be communicated to a third party, without the prior written consent of Kongsberg Discovery Canada Limited.

Warning

The equipment to which this manual applies must only be used for the purpose for which it was designed. Improper use or maintenance may cause damage to the equipment and/or injury to personnel. You must be familiar with the contents of the appropriate manuals before attempting to operate or work on the equipment.

Kongsberg Discovery disclaims any responsibility for damage or injury caused by improper installation, use or maintenance of the equipment.

Disclaimer

Kongsberg Discovery Canada Limited endeavours to ensure that all information in this document is correct and fairly stated, but does not accept liability for any errors or omissions.

Support information

If you require maintenance or repair, contact your local dealer. You can contact us by phone at +1 604 464 8144, or by email at: support.vancouver@kd.kongsberg.com. If you need information about our other products, visit <https://www.kongsberg.com/discovery/>. On our website you will also find a list of our dealers and distributors.

Table of contents

ABOUT THIS MANUAL	5
M3 SONAR	7
System description.....	8
System diagram.....	9
SAMM overview.....	10
System units.....	11
Sonar Processor.....	12
Power supply.....	12
Sonar Head.....	13
Support information.....	13
GETTING STARTED	14
Installing the M3 software.....	15
Defining the IP address on the computer's network adapter.....	16
Starting operation of the Sonar Head.....	17
Presentation overview.....	18
OPERATING PROCEDURES	20
Setting up the sensors.....	21
Configuring a rotator (optional).....	26
Running two Sonar Heads (optional).....	30
Creating an image mosaic.....	31

About this manual

The purpose of this manual is to provide instructions on how to collect image data that will be combined into a mosaic of multiple overlapping geo-referenced images.

Target audience

This publication is intended for all inexperienced and new users of the M3 Sonar system. A good understanding of system functions and controls is essential to fully take advantage of the functionality provided. A careful study of the information in this manual is highly recommended, preferably while exploring the functionality offered by the M3 Sonar system.

We assume that you are familiar with the basic setup and operation of the M3 Sonar. Familiarity with entering position and heading sensor inputs is also recommended.

License information

The M3 Software is included with the M3 Sonar system and updates are available free of charge.

SAMM is a licensed product. In order to obtain a license, contact Oceanic Imaging Consultants, Inc.

Software version

This M3 Sonar Instruction Manual complies with M3 software version 2.5.4.

This M3 Sonar Instruction Manual complies with SAMM software version 2.9.

Registered trademarks

Observe the registered trademarks that apply.

Windows® is a registered trademark of Microsoft Corporation in the United States and other countries.

M3 Sonar® is a registered trademark of Kongsberg Discovery Canada Limited in the United States and other countries.

SAMM is a trademark of Oceanic Imaging Consultants, Inc., in the United States and other countries.

We want your feedback

We always want to improve our products. We also want our end-user documentation to be comprehensive and relevant. You can help. Please provide comments, suggestions or constructive criticism to our support office. You can contact us by phone at +1 604 464 8144, or by email at: support.vancouver@kd.kongsberg.com.

M3 Sonar

Topics

[System description, page 8](#)

[System diagram, page 9](#)

[SAMM overview, page 10](#)

[System units, page 11](#)

[Support information, page 13](#)

System description

The Kongsberg Discovery M3 Sonar is a compact, versatile multibeam sonar.

Multibeam sonars have an array of transducers that simultaneously transmits pings (sound pulses) at a specified frequency to cover a large area in less time than a single-beam transducer. To generate data, computer software assigns a colour range corresponding to the amount of sound reflected off a target. The distance to the target is determined by the length of time it took to receive the transmitted acoustic pulse.



By combining the high refresh rate of a conventional multibeam sonar with an image quality comparable to a single-beam sonar, the M3 Sonar provides high-resolution images that are easy to interpret. The M3 Sonar detects objects out to 150 metres and has a 120° to 140° field of view, allowing you to see the full underwater picture in real-time.

The M3 Sonar provides wide-angle full-range situational awareness and concurrent ultra-short range imaging with dynamic focusing. For optimized obstacle avoidance, the M3 Sonar uses variable vertical beamwidth.

System diagram

The system diagram identifies the main components of a basic M3 Sonar system. Only the main connections between the units are shown. Detailed interface capabilities and power cables are not shown.

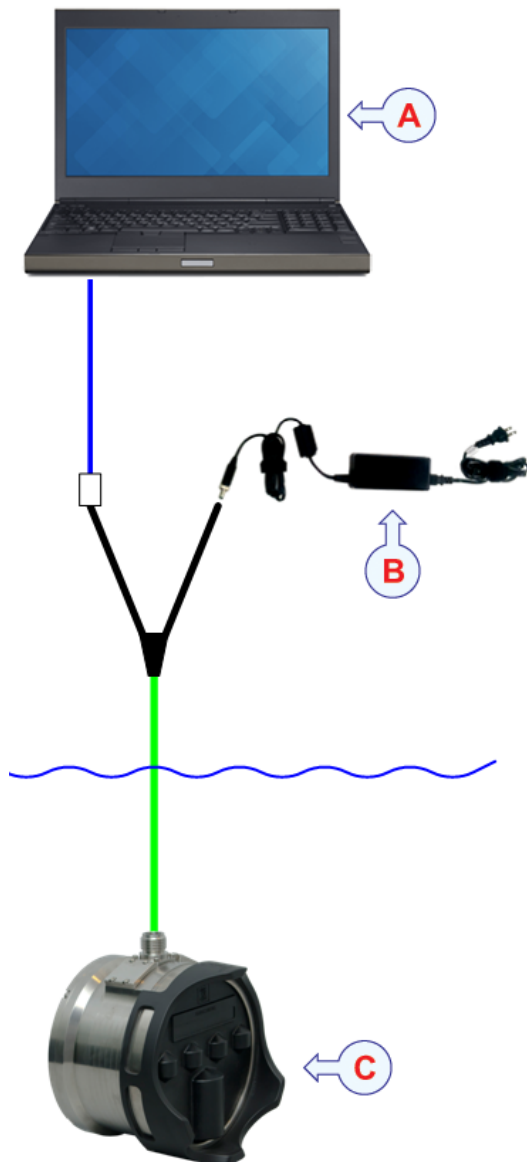

- A *Sonar Processor*
- B *Power supply*
- C *M3 Sonar Head*

SAMM overview

SAMM (Stand Alone Mosaicking Module) is a software program for real-time and playback mosaicking of underwater imagery.

While logging the raw data for playback and postprocessing, SAMM automatically creates mosaics of your sonar data over your co-registered charts or imagery.

The M3 software must be run concurrently and be connected to SAMM. All control and processing is left to the M3 software.

SAMM is designed to read sonar data, position and sensor heading, and produce a mosaic. Position and heading sensors are therefore required to create GeoTiff images. Navigation and heading sensors must be supplied to the M3 software, so that SAMM can receive position and heading included with the sonar data.

Note

NMEA 0183 sensor format is required (GGA, GLL, G GK, HDT, HDM).

The sensor accuracy will determine how well the images are overlaid in the mosaic. You must determine the sensor accuracy requirements according to your application.

System units

Topics

[Sonar Processor, page 12](#)

[Power supply, page 12](#)

[Sonar Head, page 13](#)

Sonar Processor

In this publication, the computer can also be referred to as the *Processor Unit*, and vice versa. The Sonar Processor contains the operational software, and offers the user interface that allows you to control the M3 Sonar. It is a vital part of the M3 Sonar system.

The Sonar Processor runs the M3 software that manages communication with the Sonar Head, performs all beamforming and image processing and presents the sonar imagery. The Sonar Processor communicates with the sonar through a standard Ethernet cable.

If you purchase a computer locally, make sure that the chosen model meets the functional and technical requirements. The computer must be designed for rugged use. The construction must be able to withstand the vibrations and movements of a vessel.



Power supply

The Sonar Head requires a DC power supply to run.



Normally, the DC voltage is supplied in the location where the Sonar Head is mounted, such as on a remotely operated vehicle (ROV). A small DC switching supply can be used when running the system on a surface vessel.

A test cable and power supply is available for order as an accessory. The test power supply uses a 24 VDC switching power supply.

Sonar Head

When deployed underwater, the Sonar Head transmits and receives acoustic pulses.

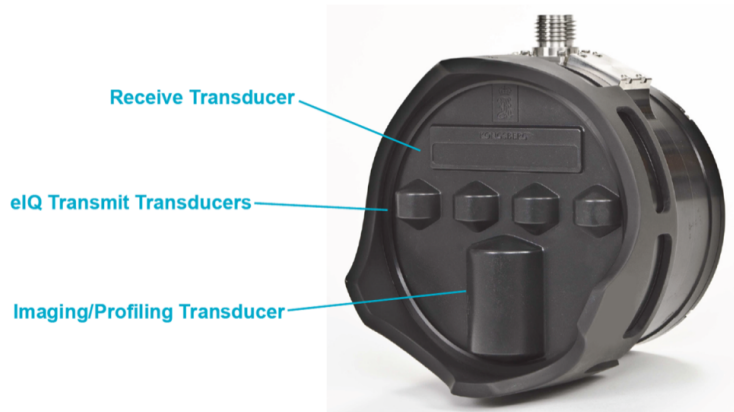

The Sonar Head includes transmit and receive transducers and the electronics to generate the transmit pulse and digitize the received signal. The sonar data is sent to the Sonar Processor using a standard Ethernet link.

Note

The Sonar Head's black polyurethane transducer is delicate. Always keep the Guard Ring and protective cover over the transducer during installation and storage.

Several different M3 Sonar models are available – your model may differ from the one shown here. For example, there are models with different depth ratings and materials, as well as models that include an integrated sound velocity sensor or high-frequency transducer.

Support information

If you need technical support for your M3 Sonar you must contact your local dealer, or our support department.

If you require maintenance or repair, contact your local dealer. You can contact us by phone at +1 604 464 8144, or by email at: support.vancouver@kd.kongsberg.com. If you need information about our other products, visit <https://www.kongsberg.com/discovery/>. On our website you will also find a list of our dealers and distributors.

Getting started

Topics

[Installing the M3 software, page 15](#)

[Defining the IP address on the computer's network adapter, page 16](#)

[Starting operation of the Sonar Head, page 17](#)

[Presentation overview, page 18](#)

Installing the M3 software

If your system is provided with a Sonar Processor, the M3 software has already been installed. If you intend to use your own computer, you must install the software yourself. We recommended installing the latest M3 software on your Sonar Processor.

Prerequisites

- You can find the software on the Kongsberg USB drive included with the system, or you can contact your local dealer or distributor to have the latest software version installed.
- If you are installing a new software version, uninstall the previous version of the M3 software before proceeding.

Note

When running the M3 software for the first time, a Windows Firewall dialog box may appear. Allow access for all networks.

Procedure

- 1 Launch the installer **M3_V0254 Setup.exe**.
- 2 Follow the installation wizard's instructions and select *Standard Installation*.

Note

Use the Dual-M3 on Same PC option only if you are using two M3 Sonars. Selecting this option will install two separate copies of the software, with each copy having its own settings. You can identify which copy you are using by observing the top header of the software presentation. The header will read either "M3 - Master Head" or "M3 - Slave Head".

- 3 Use the default folder location and check **Create a desktop icon**, then click **Next**.
- 4 Click **Yes** to install the **KML USB Converter** when prompted and follow the instructions to finish the installation process.
- 5 Pin the M3 software icon to the Windows Taskbar.
 - a Right click on the M3 software icon.
 - b Click **Pin to taskbar**.
- 6 Test the M3 software startup.
 - a Double click the M3 icon on the desktop to run the M3 software.
 - b Confirm the software finishes launching without any error windows appearing.

Defining the IP address on the computer's network adapter

The communication between the Sonar Processor and the Sonar Head is made using a high-speed Ethernet cable. If a Sonar Processor is not configured to connect to the sonar, you must define which IP Address and Subnet mask the Ethernet adapter in the Sonar Processor shall use for this communication.

Prerequisites

This procedure is made for the Microsoft® 64-bit Windows 10 operating system. It is assumed that you are familiar with the Windows® operating systems, computer technology, and interface principles.

Context

As long as you do not change the Sonar Processor to another computer, or replace the serial adapter in your Sonar Processor, you will only need to do this once.

Procedure

- 1 On the computer, close the M3 software.
- 2 Open the **Network Connections** dialog box.
 - a In the bottom-left corner of your desktop, select the Windows® search function.
 - b In the search box, type "Network Connections", and open the **Network Connections** dialog box.
 - c Right-click the network adapter you are going to use and select **Properties** on the shortcut menu.
 - d On the list of connections, select **Internet Protocol 4 (TCP/IPv4)**, and then **Properties**.
- 3 Select **Use the following IP address**, and type the IP address and network mask.

IP Address: **192.168.1.N** ("*N*" can be any number from 1 to 254, except 234, which is the Sonar Head default.)

Subnet mask: **255.255.255.0**

You can leave **Default Gateway** blank.
- 4 Select **OK** to save the settings, then close all the dialog boxes.

Starting operation of the Sonar Head

To start operation of the M3 Sonar sonar, you may need to make sure that the Sonar Head has been discovered.

Prerequisites

- The M3 software must be running.
- The sound speed has been configured in **Setup**→**System Configuration**→**Deployment**→**Master Reference**.

Procedure

- 1 Click **Setup**→**Connect** to start the Sonar Head.

Wait for “Sync OK” to appear on the status bar before collecting data. It takes two minutes to synchronize the Sonar Head clock.

Tip

*By default, the M3 software uses the computer’s time to set the Sonar Head clock (Host mode). You can change the time synchronization settings by clicking **Setup**→**System Configuration**→**Sonar Setup**→**Time Sync Mode**.*

- 2 If you see an error in the **Output Messages** window, make sure that the Sonar Head has been discovered.
 - a Click **Setup**→**System Configuration**→**Devices**→**Sonar Setup**.
 - b Click **Discover Sonar Heads** to search for the sonar on the network.

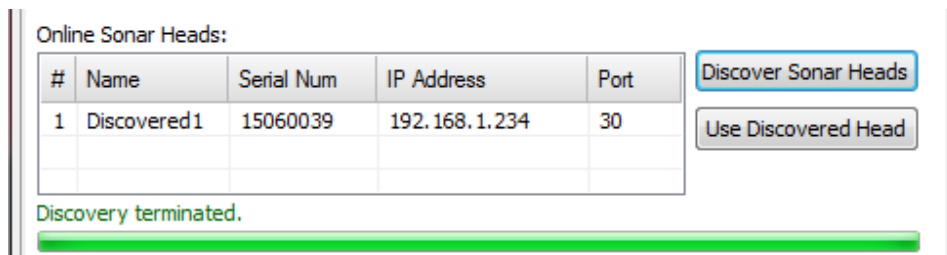

- c If the Sonar Head is found, select it, then click **Use Discovered Head**.
A discovered Sonar Head appears in the **Online Sonar Heads** list. If the Sonar Head does not appear, the Ethernet connection between the Sonar Processor and Sonar Head has not been established.
- d Click **Close**.

Presentation overview

By default, the display presentation covers the entire screen.

This M3 Sonar screen capture shows you a typical data replay situation.

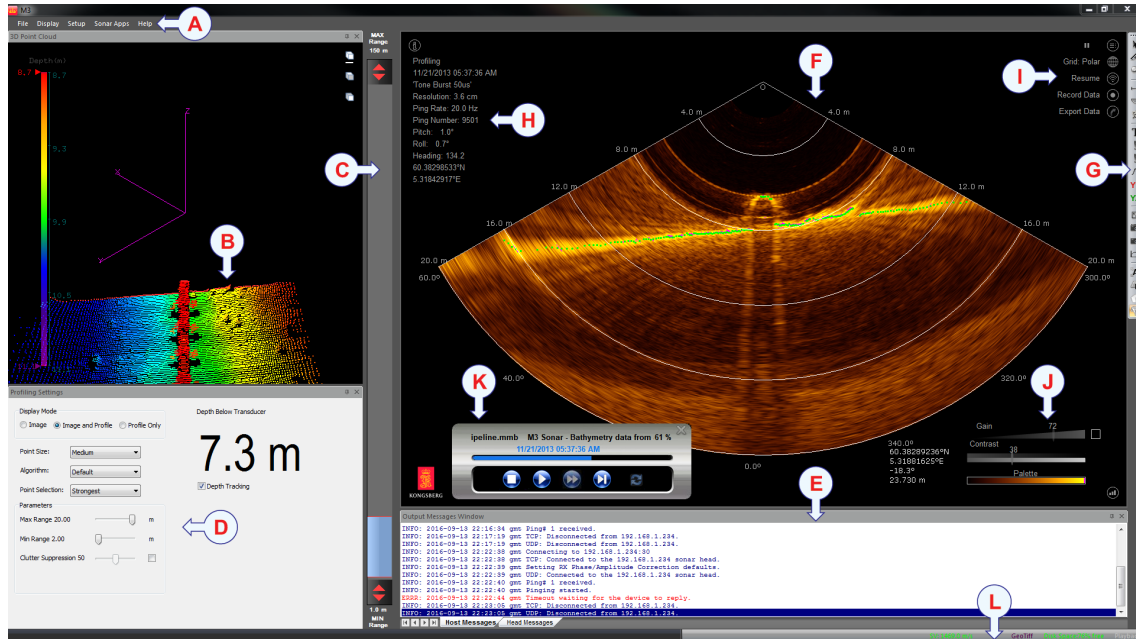

The presentation provides you with a lot of information. The sonar view presents sonar echo data. The 3D Point Cloud presents profile point data that can be rotated in three dimensions. The menu system on the top gives you easy access to all the functionality offered by the M3 software. The tool bar provides buttons for functions, filters, and sonar view overlays. The bottom **Output Messages** window and bottom status bar provide diagnostic messages.

You can resize a window by clicking on the window border, then dragging it to create a smaller or larger window. Click the pin icon on the window title bar to auto hide the window. To show the window, hover your mouse over the labelled tab that appears on the side of the presentation.

A Menu system

The menu system is located on the top of the presentation. To open any of the menus, click the menu title.

B 3D Point Cloud

Profiling mode allows you to view a real-time 3D point cloud of the sea bottom or structures under the water. You can zoom into or rotate the real-time 3D point cloud data, as well as switch to a project, top, or side view.

C Range slider bar

When the sonar is running, you can increase or decrease the range using the range slider bar to the left of the sonar view. Click the top arrows to increase or decrease the far range.

D Profiling Settings

In the **Profiling Settings** dialog box, you can choose to display only the sonar view, only the 3D Point Cloud, or both. The profile point data can be exported to a file so that third-party software can extract depth, distance, and volume measurements.

E Output Messages

The **Output Messages** window displays information, diagnostic, and error messages. There are two tabs in this window: one for host messages and one for head messages.

F Sonar view

All echo information offered by the M3 Sonar is shown in the sonar view.

G Tool bar

The tool bar provides access to useful functions, such as the ability to take a screenshot or change your TVG settings. In addition, several measuring tools are available.

H Information Widget

The **Information Widget** displays sonar pulse details as well as vessel speed, sound speed, heading, and latitude/longitude coordinates from external sensors.

I Menu Widget

The **Menu Widget** provides controls to record and export data, play or pause playback, and configure the grid.

J Display Widget

The **Display Widget** allows you to adjust the filter strength, change the display gain, and choose your echo colours. If you have a high-frequency M3 Sonar transducer, you can change the frequency using the **Display Widget**.

K Playback Console

Control playback using the **Playback Console**. You can stop, pause, fast forward, or advance through the recording one ping at a time. You can also repeat playback of the file on a never-ending loop.

L Status bar

The status bar is located at the bottom of the M3 Sonar presentation. It allows you to view the system status and disk space. You can also access detailed telemetry info.

Operating procedures

Topics

[Setting up the sensors, page 21](#)

[Configuring a rotator \(optional\), page 26](#)

[Running two Sonar Heads \(optional\), page 30](#)

[Creating an image mosaic, page 31](#)

Setting up the sensors

You will need to configure the M3 software to use the heading and position sensors, enter the Mounting Offsets, and set the Master Reference.

Prerequisites

- A surface vessel or UUV with the M3 Sonar attached looking to forward, port, or starboard.
- Position and heading sensors that are installed and connected to the M3 Sonar system.

Context

The Master Reference is the location of the sensors relative to the Sonar Head.

Note

It is critical that the mounting offsets are as accurate as possible. Significant errors in the mounting offsets will result in a blurred or severely distorted image mosaic.

Procedure

- 1 On the Sonar Processor desktop, double-click the M3 Sonar icon to start the software.
- 2 Set up your heading and position sensors.
 - a Click **Setup**→**System Configuration**→**Devices**→**Sensors Setup**.
 - b Click **Add Device**.
 - c Select *HDT* (Heading True) from the **Protocol** drop-down list.
 - d Click in the **Name** field and enter a label for the sensor (for example, *Hemisphere VS330*).
 - e Configure the serial port settings for the sensor by selecting the correct values from the drop-down lists.
 - **Port Location**
The location of the port receiving external sensor data – can be a COM port, a UDP Ethernet port, or a port on the Sonar Head.

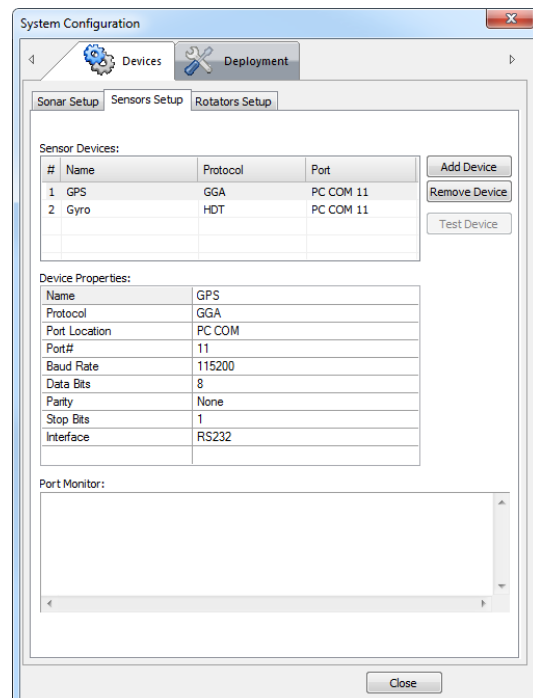

- **Port#**

This drop-down lists the available port numbers. Select the port where the device is connected.

- **Baud Rate**

Specify the baud rate (“speed”) for the serial communication. The standard baud rate defined for NMEA communication is *4800*.

- **Data Bits**

Select the number of data bits for the serial communication.

Note _____

The standard number of data bits defined for NMEA serial line communication is 8 (eight).

- **Parity**

Specify the parity for the serial communication.

Note _____

If required, a parity bit is used in a simple error detection algorithm for a serial port. Standard parity defined for NMEA serial line communication is "None".

- **Stop Bits**

This parameter is used to indicate the end of the transmission. It is usually set to *1*.

- **Interface**

This drop-down lists possible serial communication methods.

- f Click **Add Device**.
- g Select *GGA* (or other supported position format) from the **Protocol** drop-down list.
- h Click in the **Name** field and enter a label for the sensor (for example, *Hemisphere VS330*).
- i Configure the serial port settings for the sensor by selecting the correct values from the drop-down lists.
- j Select each sensor device and click the **Test Device** button.
- k Make sure that the NMEA sensor string is being displayed in the **Port Monitor** box.
- l Click **Stop Test** when done.

- 3 Measure the mounting offsets.

- a Measure and record the position and angle of the Sonar Head transducer (centre of the face) relative to your position sensor.

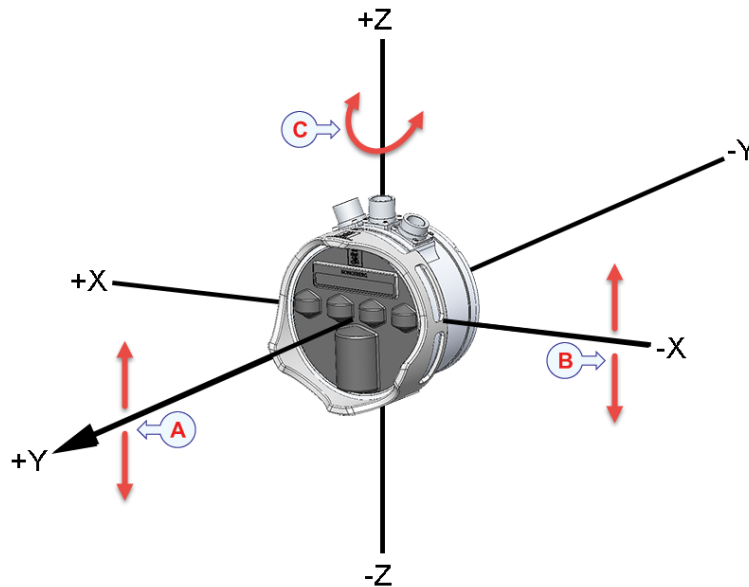

- A *Pitch* (Positive pitch means bow up.)
 B *Roll* (Positive roll means starboard side down.)
 C *Yaw* (Positive yaw means starboard turn.)
- X = to starboard
 - Y = forwards
 - Z = pointing upwards

Refer to the examples below.

Side-looking mount (Port side) tilted down 15°

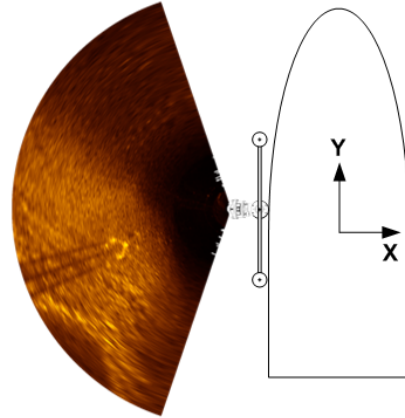
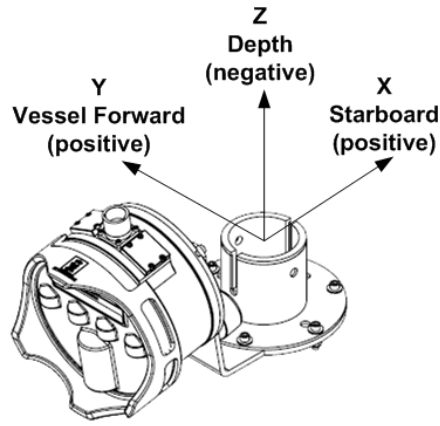

VESSEL AFT VIEW

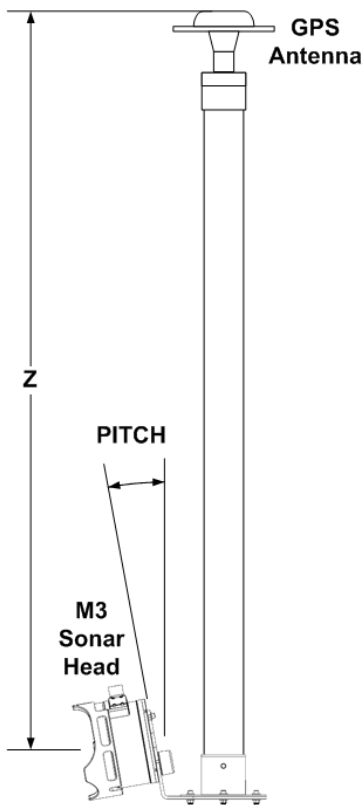

VESSEL TOP VIEW

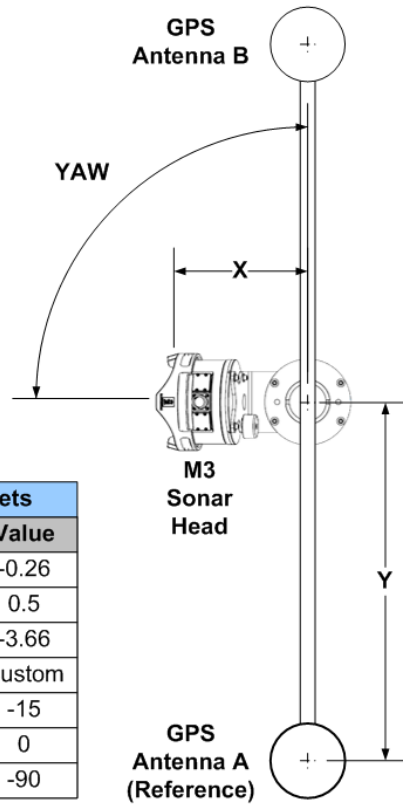

Mounting Offsets	
Parameter	Value
X Offset (m)	-0.26
Y Offset (m)	0.5
Z Offset (m)	-3.66
Orientation	Custom
Pitch Angle (°)	-15
Roll Angle (°)	0
Yaw Angle (°)	-90

Forward-looking mount tilted down 15°

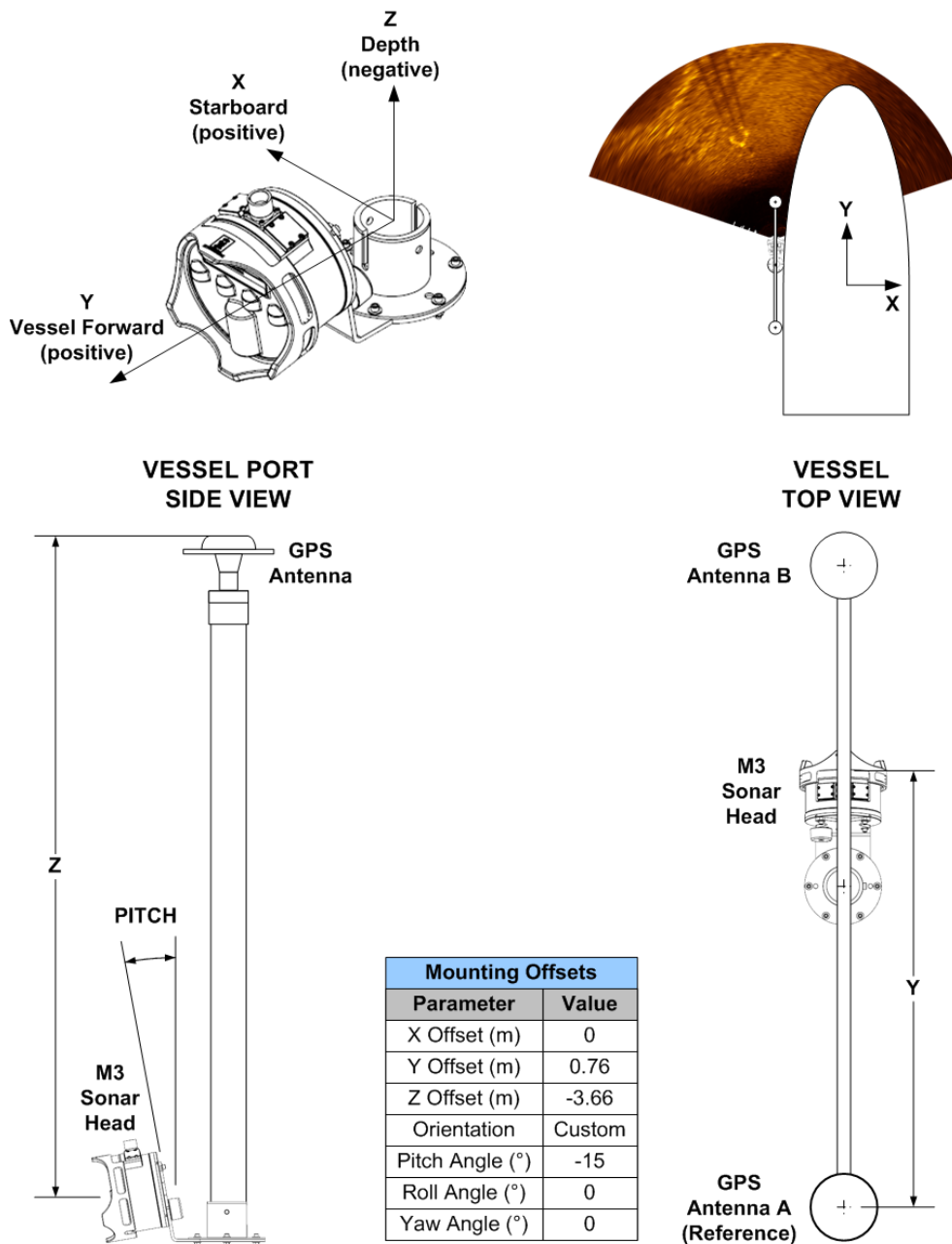

- 4 Configure the mounting offsets in the M3 software.
 - a Click **Setup**→**System Configuration**→**Deployment**→**Mounting Offsets**.
 - b Enter the X, Y, and Z offsets, as well as the Pitch Roll, and Yaw angles that you measured earlier into the **Value** fields.
- 5 Configure the Master Reference in the M3 software.
 - a Click **Setup**→**System Configuration**→**Deployment**→**Master Reference**.

- b Select the position sensor that you set up earlier (for example, Hemisphere VS330) from the **Position** drop-down list.
- c Select the heading sensor that you set up earlier (for example, Hemisphere VS330) from the **Heading** drop-down list.
- d Leave **Depth** and **Pitch/Roll** as fixed.
Pitch/Roll sensor data is not used to create a mosaic image.
- e Click the **Save As** button.
- f Enter a new configuration name (for example, *Port side looking with -15° tilt*), then click **OK**.

Further requirements

To synchronize with the computer clock, you may wish to add a sensor for ZDA input as well.

Related topics

[Creating an image mosaic, page 31](#)

Configuring a rotator (optional)

You may configure the M3 software to use an optional rotator.

Prerequisites

- Rotator connected to the M3 software.
- A surface vessel or UUV with the M3 Sonar attached looking to forward, port, or starboard.
- Position and heading sensors that are installed and connected to the M3 Sonar system.

WARNING

Before running the rotator, make sure it is safe to do so. Make sure that all parts are assembled and that there is nothing near the rotator that could be pinched or impacted.

Context

You can use a single-axis rotator with the M3 Sonar for image mosaic applications. Using a rotator will allow you to optimize the image by adjusting the tilt of the Sonar Head. You can easily switch the configuration from forward-looking imaging to bathymetry mode (for bottom profiling).

Note

The OE10-102 and OE10-103 have two user-configurable hard stops to limit the rotation sector.

Procedure

- 1 On the Sonar Processor desktop, double-click the M3 Sonar icon to start the software.
- 2 Create a new deployment configuration.
 - a Click **Setup**→**System Configuration**→**Deployment**→**Master Reference**.
 - b Click the **Save As** button.
 - c Enter a new configuration name (for example, *Forward Imaging with Rotator Tilt*), then click **OK**.

- 3 Set up the rotator.
 - a Click **Setup**→**System Configuration**→**Devices**→**Rotators Setup**.
 - b Click **Add Device**.
 - c Select *Kongsberg OE10-103* (single axis) from the **Unit** drop-down list.
 - d Configure the serial port settings for the rotator by selecting the correct values from the drop-down lists.

Note

The default baud rate is 9600 bps.

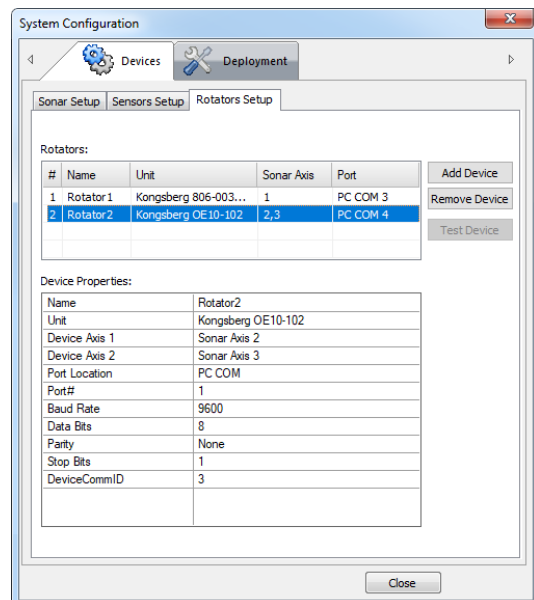

- e Click in the **Name** field and enter a label for the rotator (for example, *Rotator 1*).
- f Click the **Test Device** button.
Observe that the **Rotator Test** dialog box opens.
- g Select *Pan/Tilt Control* from the **Rotator Control Dialog Type** drop-down list at the bottom of the dialog box.
- h Select **Close** to save the chosen settings and close the dialog box.
- i Click **Setup**→**Connect** to start the Sonar Head.
Observe that the **Rotator Control** dialog box opens.
- j Click the arrow buttons to adjust the rotator position and move the Sonar Head.

- k Click the **Calibrate** button to correctly align the rotator (reset the zero index) after turning it on.

Note _____

The calibration will fail if there are no hard stops.

4 Configure the mounting offsets in the M3 software.

- a Click **Setup**→**System Configuration**→**Deployment**→**Mounting Offsets**.

- b In the **Rotators** section, select the rotator that you set up earlier.

Tip _____

The rotator axis will flash in the 3D view.

- c Enter in the radius and angle offset values.

The radius offset is necessary if your Sonar Head is attached to the rotator with an arm. The length of the arm can be entered as the radius.

Entering an angle is not necessary if the transducer face of the Sonar Head is aligned with the rotator. However, if the Sonar Head is installed at an angle to the rotator, then enter that value here.

Refer to the example below.

OE10-103 Rotator forward-looking mount

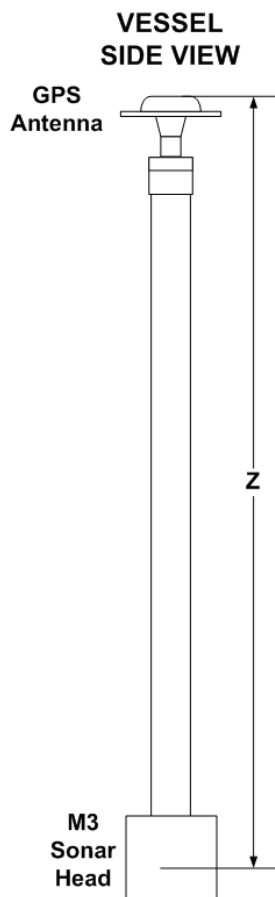
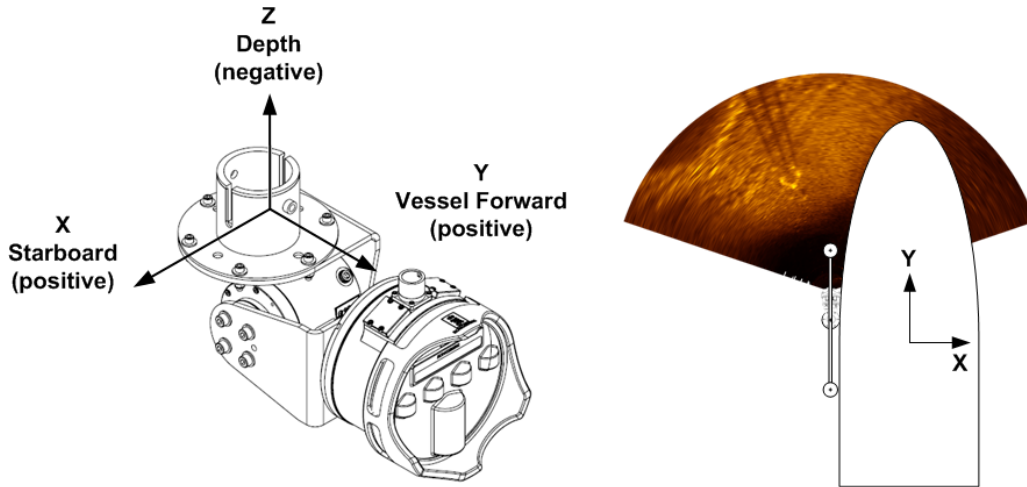

Mounting Offsets	
Parameter	Value
X Offset (m)	0
Y Offset (m)	0.74
Z Offset (m)	-3.66
Orientation	Custom
Pitch Angle (°)	0
Roll Angle (°)	0
Yaw Angle (°)	0
Axis #1 - Rotator	
Parameter	Value
Radius (m)	0.24
Angle (°)	0
Axis #2	
Parameter	Value
Radius (m)	0
Angle (°)	0
Axis #3	
Parameter	Value
Radius (m)	0
Angle (°)	0

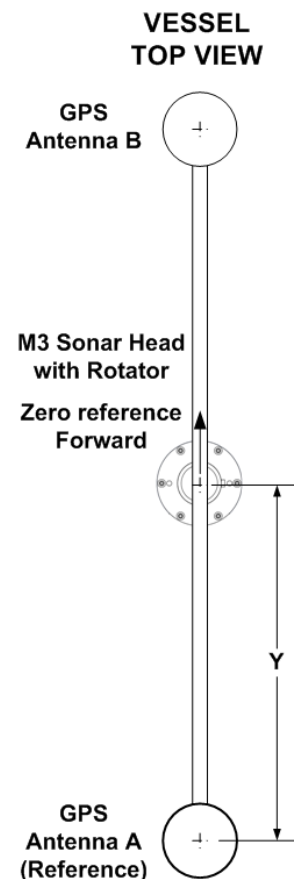

Running two Sonar Heads (optional)

You can configure the M3 software to run two Sonar Heads.

Prerequisites

- Two M3 Sonar Heads fitted with the optional synchronization connector.
- A synchronization interconnect cable for the M3 Sonar Heads.
- A surface vessel or UUV with the Sonar Heads attached looking to forward, port, or starboard.
- Position and heading sensors that are installed and connected to each instance of the M3 software running the Sonar Heads.
- There is an option during the M3 software installation to install a single head or dual heads. Reinstall the M3 software for dual heads when running two Sonar Heads.

Note

Two instances of the M3 software are required for dual-head mode.

Context

The M3 Sonar has an optional synchronization connector on the Sonar Head. When the M3 Sonar pings, it generates a 100 μ s sync pulse. This pulse can be used to synchronize multiple M3 Sonar Heads (or other devices).

To synchronize multiple Sonar Heads, you must set up Master/Slave mode. By default, the M3 Sonar is configured as the Master. For dual-head operation, one of the sonars must be configured as the “slave” in the M3 software.

Note

Once the Sonar Heads are connected, the “slave” sonar will not ping. The “slave” sonar will wait to update the display until the “master” sonar is running.

Procedure

- 1 Run the instance of M3 software used for the “slave” sonar.
- 2 Click **Setup**→**System Configuration**→**Devices**→**Sonar Setup**.
- 3 Select *Slave - External Pulse Triggered* from the **Trigger Mode** drop-down list.
- 4 Select **Close** to save the chosen settings and close the dialog box.
- 5 Run the instance of M3 software used for the “master” sonar.
- 6 Click **Setup**→**Connect** to start the Sonar Head.

Once the “master” sonar is running, it will synchronize with the “slave” sonar.

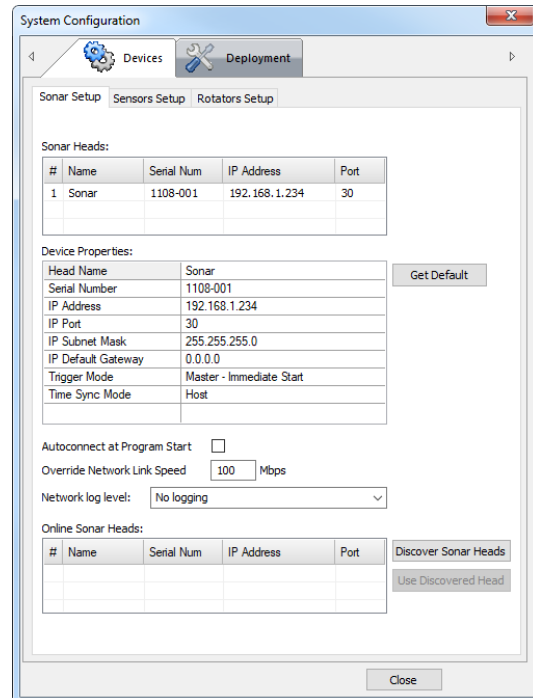

Creating an image mosaic

Image data collected with the M3 Sonar can be sent from the M3 software to the SAMM software and combined into an image mosaic.

Prerequisites

- A surface vessel or UUV with the M3 Sonar attached looking to forward, port, or starboard.
- Position and heading sensors that are installed and connected to the M3 Sonar system. To create a large-area mosaic, position and heading sensors are required to geo-reference the image data so that it can be placed correctly by post-processing software.
- Sensor setup must be complete. You will need to configure the M3 software to use the heading and position sensors, enter the Mounting Offsets, and set the Master Reference.
- You must have set up the SAMM software. An OIC-provided dongle with the latest drivers must be plugged into your computer’s USB port.

Context

There are two basic mounting configurations for the M3 Sonar: Forward Looking and Side Looking.

The Side-Looking configuration has the advantage of achieving higher-resolution images. Multibeam sonars have the narrowest beam in the centre of the array. By reducing the width of the sonar image, you can keep the best resolution data and discard the rest.

Here are some examples of side-looking applications. For these applications, the M3 Sonar can be facing port or starboard.

- Survey of a square or rectangular area using multiple parallel lines.
- Survey of a pier using one or two lines parallel to the pier.
- Survey around a structure (or a shoreline) using one pass around the structure at some distance.

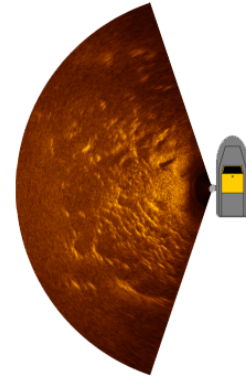

The Forward-Looking configuration has the advantage of coverage that is almost twice as wide. Also, you can trim the forward-looking image vertically instead of horizontally if needed. Tilting the sonar downward can improve bottom coverage by reducing the first point of contact with the sonar beam and the sea bottom. If a surface vessel is used, then a 15° downward tilt bracket is recommended. For optimal bottom coverage, you can also adjust the tilt with a rotator.

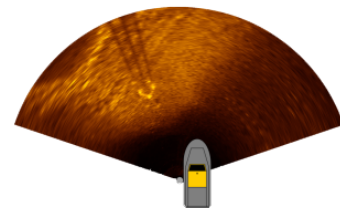

Here are some examples of forward-looking applications.

- Survey of a square or rectangular area using multiple parallel lines.
- Forward-looking navigation and survey using one or more survey lines.

Procedure

- 1 Connect to the Sonar Head using the M3 software.
 - a Turn on the position and heading sensors.
 - b Power up the Sonar Head using the power supply.
 - c Turn on the computer.

Wait while the operating system loads.
 - d Log in to Windows.
 - e On the Sonar Processor desktop, double-click the M3 Sonar icon to start the software.

- f Click **Setup**→**Connect** to start the Sonar Head.

Observe that the text “Active” appears in the lower-right corner of the status bar.

- 2 Make sure that the position and heading data is displayed in the **Information Widget**.

Tip _____

*Click the “i” icon in the top-left corner of the sonar view to open the **Information Widget**.*

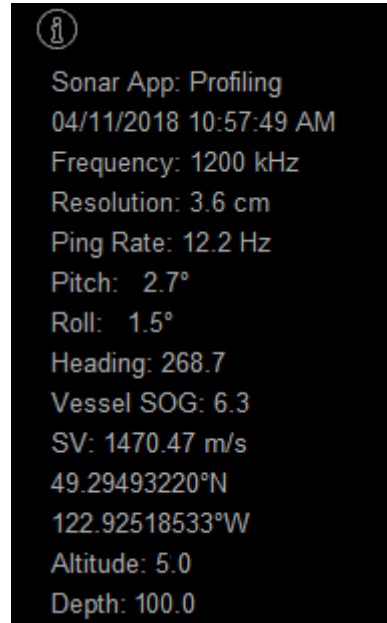

- 3 Choose the sonar range.

- a Right-click inside the sonar view to display the range menu.

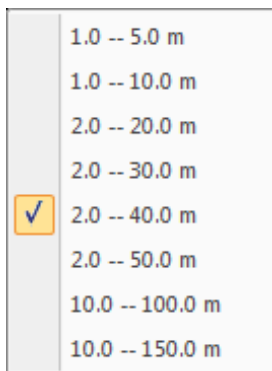

- b Select the desired near and far range from the menu.

Tip _____

You can increase or decrease the range using the range slider bar to the left of the sonar view. Click the top arrows to increase or decrease the far range.

- 4 Click **Sonar Apps** and select an appropriate sonar application from the list.

Note _____

We recommend a maximum vessel speed of two knots for EIQ mode and 0.5 knots for EIQ - Fine mode. We recommend a maximum vessel speed of five knots for imaging applications.

- 5 Begin the survey run and start recording the sonar data.

- a Click the circular icon in the top-right corner of the sonar view to open the **Menu Widget**.

- b Click **Record Data** or press **F4** to start recording.

When recording is in progress, a flashing recording icon will appear in the top-right corner of the sonar view. The recording filename will also appear here. Observe the percentage of disk space free for recording on the far right of status bar.

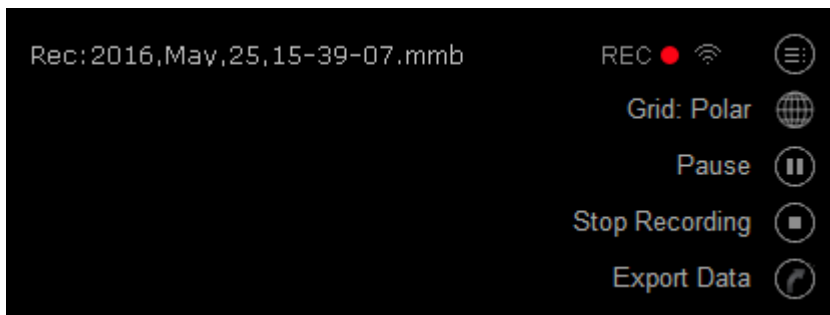

- 6 Connect the SAMM software to the M3 software.
 - a Run the SAMM software, create a project and click on the **Add Data** icon.



- b Click **Connect to...** from the drop-down menu.

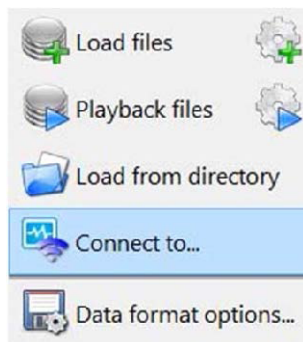

- c Select **Kongsberg M3** from the supported sensors list, then click the **Load** button.



Observe that a **Connect to Sonar** dialog box opens.

Connect to Sonar - SAMM v2.7.942 32-bit (OIC detected)

 SAMM communicates with the Kongsberg M3 software via TCP/IP, which also provides position and heading. Sonar setup is done through the M3 software.

Resolution cm 

Use ground range 

Use course for heading 

Invert beams 

Sonar network configuration

Network interface 

IP address . . . 

Port 

Position and heading 



- d If necessary, adjust the processing parameters.
- If SAMM and the M3 software are running on the same computer, do not change the IP address from 127.0.0.1. If the M3 software is running on a different computer networked to the SAMM computer, select an appropriate network from the **Network interface** drop-down list. Then, enter the IP address of the computer running the M3 software into the **IP address** field.
 - Do not change the port number from 20001 unless you change it in the M3 software. If you change the port in the M3 software, enter the matching port number into the **Port** field.
 - By default, SAMM expects position and heading data to be provided by the M3 software. However, you can choose to receive the data directly from the navigation sensors.

- e Click the **Connect** button.

SAMM will begin collecting, recording, and mosaicking your data. SAMM will connect to the M3 software to receive data automatically.

- f Monitor the connection status in the Device status popup and in the status bar on the bottom left.

Acquisition begins automatically. SAMM flashes a warning if it is not recording.

- g Click the **Record** icon to start recording.



- h Run the survey in the desired area.

- i When done, click the **Record** icon again to stop recording.

Tip _____

Refer to the SAMM User Manual for more information.

Related topics

[Setting up the sensors, page 21](#)

Index

A		
about		
comments	6	
constructive criticism	6	
feedback	6	
registered trademarks	5	
software license	5	
software version	5	
suggestions	6	
target audience	5	
this publication	5	
C		
comments		
send us	6	
configuring		
rotator	26	
connecting		
sonar head	17	
constructive criticism		
send us	6	
creating		
image mosaic	31	
D		
defining		
IPAddress	16	
Defining the IP address on the network adapter	16	
description		
system	8	
diagram		
system	9	
display organisation		
description	18	
display views		
description	18	
E		
Ethernet adapter		
Defining the IP address on the network adapter	16	
F		
feedback		
send us	6	
H		
how to		
configure a rotator	26	
connect to the sonar	17	
create an image mosaic	31	
Defining the IP address on the network adapter	16	
install the operational software	15	
run two sonar heads	30	
set up the sensors	21	
I		
image mosaic		
creating	31	
information		
support	13	
installation		
software	15	
introduction		
power supply	12	
Sonar Head	13	
Sonar Processor	12	
IPAddress		
defining	16	
K		
Kongsberg Discovery		
support	13	
L		
license information		
software	5	
M		
M3 Sonar		
system diagram	9	
N		
network adapter		
Defining the IP address on the network adapter	16	
O		
office		
support	13	
operational software		
installation	15	
overview		
power supply	12	
SAMM	10	
Sonar Head	13	
Sonar Processor	12	
P		
power supply		
introduction	12	
overview	12	
purpose	12	
presentation		
description	18	
procedure		
configuring a rotator	26	

connecting to the sonar.....	17	this publication.....	5
creating an image mosaic.....	31	about.....	5
Defining the IP address on the network		purpose.....	5
adapter.....	16	target audience.....	5
installing the operational software.....	15	this user manual	
running two sonar heads.....	30	about.....	5
setting up the sensors.....	21	purpose.....	5
purpose		target audience.....	5
power supply.....	12	two sonar heads	
Sonar Head.....	13	running.....	30
Sonar Processor.....	12		
this publication.....	5		

R

registered trademarks.....	5
rotator	
configuring.....	26
running	
two sonar heads.....	30

S

SAMM	
overview.....	10
sensors	
setting up.....	21
setting up	
sensors.....	21
software	
installation.....	15
software license	
about.....	5
software version	
about.....	5
sonar head	
connecting.....	17
Sonar Head	
introduction.....	13
overview.....	13
purpose.....	13
sonar presentation	
description.....	18
Sonar Processor	
introduction.....	12
overview.....	12
purpose.....	12
Sonar Setup dialog box	
connecting to the sonar.....	17
suggestions	
send us.....	6
support information.....	13
SW	
software version.....	5
SW license	
about.....	5
system	
description.....	8
diagram.....	9
system software	
installation.....	15

U

user interface	
description.....	18

T

target audience	
-----------------	--

©2024 Kongsberg Discovery Canada Limited